

72

HIGH PERFORMANCE POWERED CARPET PULLER INSTRUCTION MANUAL



Caution: Read Manual Before Operating Machine

Table of Contents

Table of Contents	3
Features and Specifications	4
Safety	5-9
Safety.....	5-6
Grounding.....	7
Extension Cords	7-8
General Safety.....	9
Machine Operation	10-15
Transporting.....	10
Set Up.....	10-11
Machine Inspection.....	11
General Operation	12-14
Rope	15
Machine Start Up Procedure	16
Maintenance	17-18
Preventative Maintenance	17
Cleaning.....	17
Rope	17
Pull Bar	17
Gripper Strips.....	18
Replacing Gripper Strips.....	18
Lubrication	18
Adding Oil	18
Changing Oil.....	18
Changing the Output Oil Seal	18
Troubleshooting Guide	19-20
Complete Parts List	21
Parts List & Diagrams	22-29
Screen	22
Pulley.....	22
Pull Bar	22
Wheel & Gear Reduced.....	23
Pin.....	23
Gear Reducer	24
Controller Parts.....	25
Cords	25
Instruction Tube	25
Rope and Drive Shaft	26
Pillow Block Bearing Parts.....	26
Motor.....	26
Gripper Strip	27
Labels	28-29
Guarantee	29

Features and Specifications

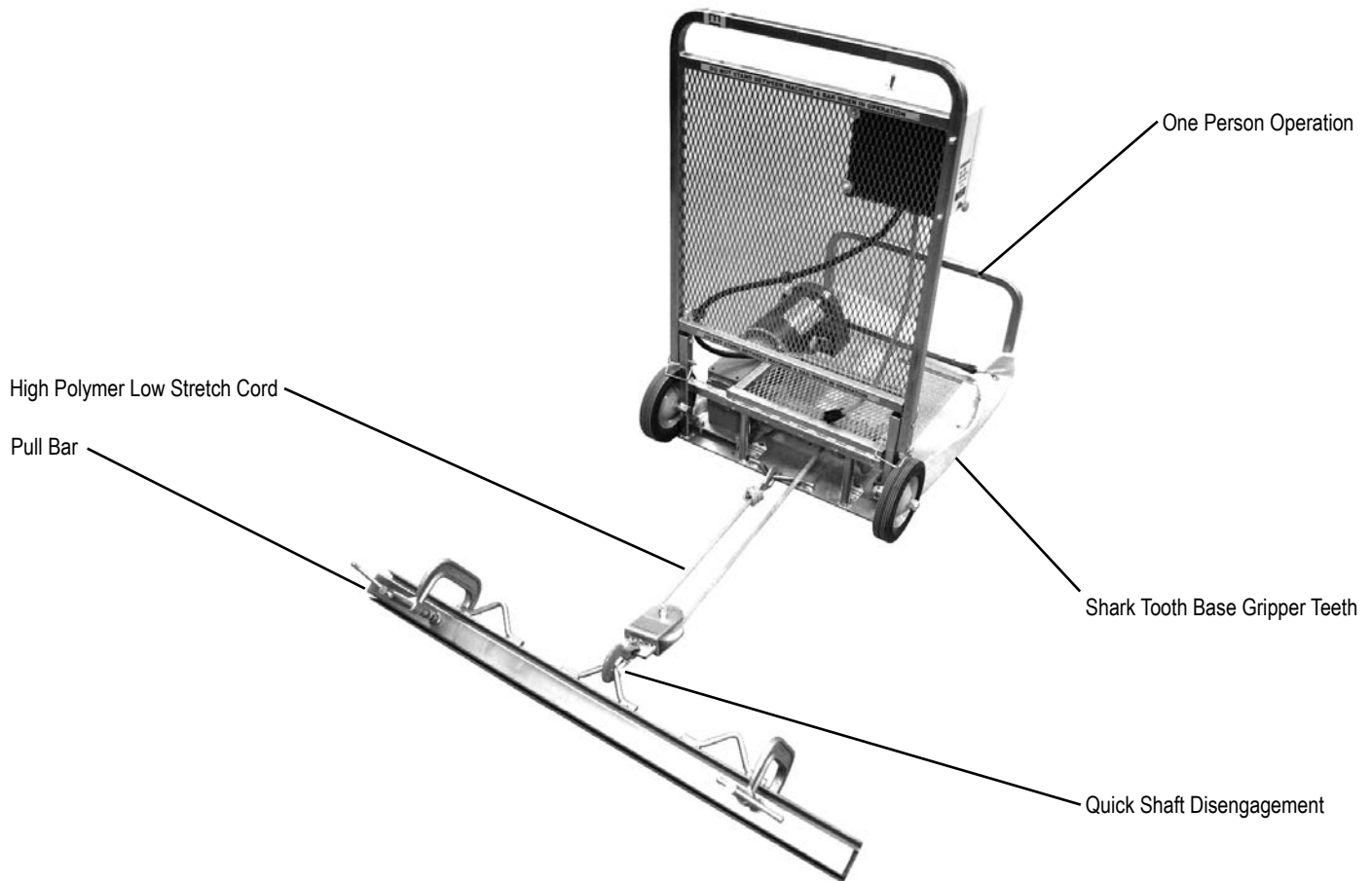

FEATURES

High Polymer Low-Stretch Cord - non-nylon low stretch high polymer cord designed for safer winch application (no cable).

Quick Shaft Disengagement - for fast rehooks, you do not have to wait for the winch.

One Person Operation - cuts normal labor to a fraction, easy to use on any job size.

Pull Bar - strongest built pull bars in the industry.

Shark Tooth Base Gripper Teeth - have a super hold even on flat carpet.

Product Specifications

Width	Length	Height	Weight	Speed	RPM	Volts	HP	Amps-Full Load
29.5"	34"	42" (w/ screen) 10" (folded down)	190 lbs.	Up to 30 ft/min	1740	110	1.5	5

READ AND SAVE ALL INSTRUCTIONS FOR FUTURE USE. Before use, be sure everyone operating this equipment reads and understands this manual as well as any labels packaged with or attached to the tool.

1. **KNOW YOUR EQUIPMENT:** Read this manual carefully to learn equipment applications and limitations as well as potential hazards associated with this type of equipment.
2. **GROUND YOUR TOOL:** See Grounding (page 7).
3. **AVOID DANGEROUS ENVIRONMENTS:** Do not use in rain, damp or wet locations, or in the presence of explosive atmospheres (gaseous fumes, dust or flammable materials). Remove materials or debris that may be ignited by sparks.
4. **KEEP WORK AREA CLEAN AND WELL LIT:** Cluttered, dark work areas invite accidents.
5. **DO NOT USE ON STEPS.**
6. **DRESS PROPERLY:** Do not wear loose clothing. These may be caught in moving parts. When working outdoors, wear rubber gloves and insulated non-skid footwear. Keep hands and gloves away from moving parts.
7. **USE SAFETY EQUIPMENT:** Everyone in the work area should wear safety goggles or glasses complying with current safety standards. Wear hearing protection during extended use and a dust mask for dusty operations. Hard hats, face shields, safety shoes, etc. should be worn when specified or necessary.
8. **KEEP BYSTANDERS AWAY:** Children and bystanders should be kept at a safe distance from the work area to avoid distracting the operator and contacting the tool or extension cord. Operator should be aware of who is around them and their proximity.
9. **PROTECT OTHERS IN THE WORK AREA:** Provide barriers or shields as needed to protect others from debris.
10. **USE PROPER ACCESSORIES:** Using accessories that are not recommended may be hazardous. Be sure accessories are properly installed and maintained. Do not delete a guard or other safety device when installing an accessory or attachment.
11. **CHECK FOR DAMAGED PARTS:** Inspect guards and other parts before use. Check for misalignment, binding of moving parts, improper mounting, broken parts and any other conditions that may affect operation. If abnormal noise or vibration occurs, turn the tool off immediately and have the problem corrected before further use. Do not use damaged equipment. Tag damaged tools "DO NOT USE" until repaired. A guard or other damaged parts should be properly repaired or replaced. For all repairs, insist on only identical National replacement parts.
12. **REMOVE ALL ADJUSTING KEYS AND WRENCHES:** Make a habit of checking that the adjusting keys, wrenches, etc. are removed from the tool before turning it on.
13. **GUARD AGAINST ELECTRIC SHOCK:** Prevent body contact with grounded surfaces such as pipes, radiators, ranges and refrigerators. When making cuts, always check the work area for hidden wires or pipes. Hold your tool by insulated nonmetal grasping surfaces. Use a Ground Fault Circuit Interrupter (GFCI) to reduce shock hazards.
14. **AVOID ACCIDENTAL STARTING:** Be sure equipment is turned off before plugging it in. Do not use a tool if the power switch does not turn the tool on and off.
15. **DO NOT FORCE EQUIPMENT:** Equipment will perform best at the rate for which it was designed. Excessive force only causes operator fatigue, increased wear and reduced control.
16. **KEEP HANDS AWAY FROM ALL CUTTING EDGES AND MOVING PARTS**
17. **WEAR GLOVES WHEN CHANGING ACCESSORIES**
18. **DO NOT ABUSE CORD:** Never unplug by yanking the cord from the outlet. Pull plug rather than cord to reduce the risk of damage. Keep the cord away from heat, oil, sharp objects, cutting edges and moving parts.
19. **DO NOT OVERREACH; MAINTAIN CONTROL:** Keep proper footing and balance at all times. Maintain a firm grip.
20. **STAY ALERT:** Watch what you are doing, and use common sense. Do not use when you are tired, distracted or under the influence of drugs, alcohol or any medication causing decreased control.

Safety

21. **STARTING MACHINE:** On/off switch must be in off position before connecting to power source.
22. **UNPLUG EQUIPMENT:** When it is not in use, unplug tool before changing accessories or performing recommended maintenance.
23. **MAINTAIN EQUIPMENT CAREFULLY:** Keep handles dry, clean and free from oil and grease. Keep cutting edges sharp and clean. Follow instructions for lubricating and changing accessories. Periodically inspect tool cords and extension cords for damage. Have damaged parts repaired or replaced.
24. **STORE IDLE EQUIPMENT:** When not in use, store in a dry, secured place. Keep away from children.
25. **MAINTAIN LABELS AND NAMEPLATES:** These carry important information. If unreadable or missing, contact National for a free replacement.
26. **MACHINE IS HEAVY, DO NOT DROP.**
27. **WHEN OPERATING MACHINE, TETHER CORD MUST BE CONNECTED TO OPERATOR.**
28. **DO NOT ALLOW:** the rotating plates to come into contact with the supply cord.
29. **REGULARLY EXAMINE THE SUPPLY CORD FOR DAMAGE** such as cracking or aging. If damage is found, replace the cord before further use. Only replace the supply cord with the type specified in the instruction manual.



WARNING: EXPOSURE TO DUST MAY CAUSE RESPIRATORY AILMENTS. USE APPROVED NIOSH OR OSHA RESPIRATORS, SAFETY GLASSES OR FACE SHIELDS, GLOVES AND PROTECTIVE CLOTHING. PROVIDE ADEQUATE VENTILATION TO ELIMINATE DUST, OR TO MAINTAIN DUST LEVEL BELOW THE THRESHOLD LIMIT VALUE FOR NUISANCE DUST AS CLASSIFIED BY OSHA.



WARNING: ELECTRICAL CORDS CAN BE HAZARDOUS. MISUSE CAN RESULT IN FIRE OR DEATH BY ELECTRICAL SHOCK. READ CAREFULLY AND FOLLOW ALL DIRECTIONS.



WARNING: ONLY USE THE SOCKET OUTLET ON THE MACHINE FOR PURPOSE SPECIFIED IN THE INSTRUCTION MANUAL.

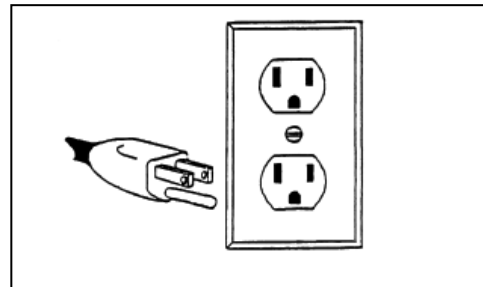

FIG. A

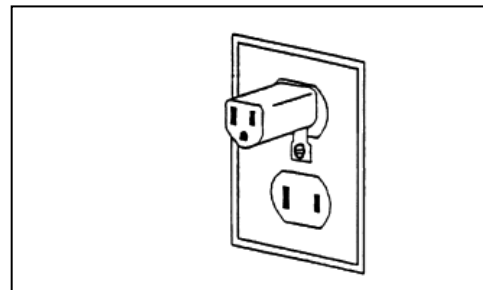

FIG. B

GROUNDING

Tools marked “Grounding Required” have a three wire cord and three prong grounding plug. The plug must be connected to a properly grounded outlet (See Figure A). If the tool should electrically malfunction or break down, grounding provides a low resistance path to carry electricity away from the user, reducing the risk of electric shock.

The grounding prong in the plug is connected through the green wire inside the cord to the grounding system in the tool. The green wire in the cord must be the only wire connected to the tool's grounding system and must never be attached to an electrically “live” terminal.

Your tool must be plugged into an appropriate outlet, properly installed and grounded in accordance with all codes and ordinances. The plug and outlet should look like those in Figure A.

Figure B illustrates a temporary adapter available for connecting grounded plugs (Figure A) to two prong outlets. The green rigid ear or lug extending from the adapter must be connected to a permanent ground such as a properly grounded outlet box or receptacle. Simply remove the center screw from the outlet, insert the adapter and reattach the screw through the green grounding ear to the outlet. If in doubt of proper grounding, call a qualified electrician. A temporary adapter should only be used until a properly grounded outlet can be installed by a qualified electrician. The Canadian Electrical Code prohibits the use of temporary adapters.

EXTENSION CORDS

Grounded tools require a three wire extension cord. Double insulated tools can use either a two or three wire extension cord. As the distance from the supply outlet increases, you must use a heavier gauge extension cord. Using extension cords with inadequately sized wire causes a serious drop in voltage, resulting in loss of power and possible tool damage.



WARNING: ELECTRICAL CORDS CAN BE HAZARDOUS. MISUSE CAN RESULT IN FIRE OR DEATH BY ELECTRICAL SHOCK. READ CAREFULLY AND FOLLOW ALL DIRECTIONS.

The smaller the gauge number of the wire, the greater the capacity of the cord. For example, a 10 gauge cord can carry a higher current than a 12 gauge cord. When using more than one extension cord to make up the total length, be sure each cord contains at least the minimum wire size required. If you are using one extension cord for more than one tool, add the nameplate ampere and use the sum to determine the required minimum wire size.

Safety

GUIDELINES FOR USING EXTENSION CORDS

- If you are using an extension cord outdoors, make sure it is marked with the suffix “W-A” (“W” in Canada) to indicate that it is acceptable for outdoor use.
- Be sure your extension cord is properly wired and in good electrical condition. Always replace a damaged extension cord or have it repaired by a qualified person before using it.
- Protect your extension cords from sharp objects, excessive heat and damp or wet areas.
- Keep away from water. Do not use if wet. 
- Inspect thoroughly before each use. DO NOT USE IF DAMAGED.
- Make sure equipment is not running before disconnecting cord.
- FULLY INSERT plug into outlet.
- Do not remove, bend or modify any metal prongs or pins of cord.
- Do not use excessive force to make connections.
- Do not connect a three prong plug to a two-hole cord.
- Avoid overheating. Uncoil cord and do not cover it with any material.
- Do not walk on cord.
- Do not drive, drag or place objects over cord.
- Minimum 10 gauge cord, 50 ft maximum length.
- Regularly examine the supply cord for damage, such as cracking or aging. If damage is found, replace the cord before further use.
- Only replace the supply cord with the type specified in the instruction manual.



WARNING: KNOW AND UNDERSTAND BEFORE OPERATION. FAILURE TO DO SO COULD CAUSE DAMAGE TO EQUIPMENT OR BODILY INJURY.

GENERAL SAFETY

- Operator or support personnel should never stand in line of pull in case of rope breakage or the pull bar should let loose. Failure to do so could cause serious bodily injury or death.
- Manual should be kept with machine in supplied holder for access by operator at all times.
- Always have remote switches in hand. Do not allow yourself or others to become entangled in pulley, rope, winding shaft or pull bar.
- Only qualified, trained personnel should operate this unit.
- Pulley should be inspected before each use. Loose or damaged parts should be replaced immediately. Failure to do so could cause equipment damage or serious injury.
- Rope should be inspected. Worn or cut rope should be replaced with (rope dia. 3/8", 13,900 lbs. minimum test, 6% to 8% stretch) Nationals Replacement Rope stock #71-P33. Failure to do so could cause damage to equipment or bodily injury.
- Switches, cord, plug and receptacle should be inspected. (Disconnect power before repairs to prevent electrical shock). Unplug when not in use. Do not use if defective. Switches should return to off when released.
- Drive shaft should engage and disengage freely. Grease both ends of drive shaft on an 'as needed' basis or once a year. Oil level should be checked in gear box once a year or if gear box begins to run excessively loud or an oil leak is noticed.
- Inspect pulley, pulley wheel hook, hook securing pin and pulley housing. Replace if damaged. Do Not use if damaged.
- Power control box, motor and switches should be completely enclosed at all times with no exposed wiring.
- Disconnect power from unit before servicing. Failure to do so can cause electrical shock.
- Only use National components (ie. rope, pulley, switch, etc.). Failure to do so could cause damage or serious injury.
- Always be aware of support personnel and their proximity when in operation.



WARNING: KNOW AND UNDERSTAND BEFORE OPERATION. FAILURE TO DO SO COULD CAUSE DAMAGE TO EQUIPMENT OR BODILY INJURY.



WARNING: FAILURE TO FOLLOW ANY OF THE ABOVE INSTRUCTIONS COULD CAUSE DAMAGE TO MACHINE, DAMAGE TO PROPERTY OR SERIOUS BODILY INJURY OR DEATH.

Machine Operation



FIG. C



FIG. D



FIG. E

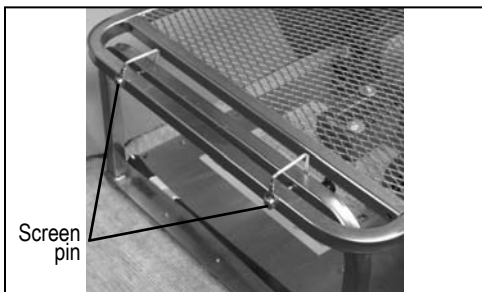

FIG. F

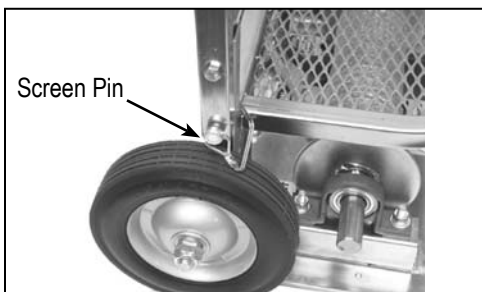

FIG. G

TRANSPORTING

1. Make sure Gripper Strips are covered with protective cover when transporting or when machine is not in use. Failure to do so could cause property damage or bodily injury.
2. Use caution not to get scratched on sharp gripper pins. Failure to do so could cause bodily injury.
3. Screen should be folded down for transport mode and secured with screen pins (See Figure C).
4. When machine is not in use, lay machine down flat to safely store (See Figure D). Failure to do so could cause machine or property damage or bodily injury. Keep pin guard cover in place when machine is not in use.
5. When machine is being transported, lay machine flat (See Figure D). Secure machine to wall of truck. Failure to do so could cause damage to vehicle, machine or bodily injury. Keep pin guard cover in place when machine is being transported.
6. To easily move machine on job-site, lean machine back onto wheels to easily roll (like a two wheel dolly), holding screen as a handle (See Figure E). Remember to release any pressure from rope before trying to move or reposition machine.
7. Do not leave machine standing-up freely (See Figure C). Machine is tippy and could fall over causing damage to machine and/or bodily injury.



WARNING: DO NOT LEAVE MACHINE STANDING-UP FREELY.



WARNING: FAILURE TO FOLLOW ANY OF THE ABOVE INSTRUCTIONS COULD CAUSE DAMAGE TO MACHINE, DAMAGE TO PROPERTY OR SERIOUS BODILY INJURY OR DEATH.

SET UP

Read instruction manual and view enclosed VCR instruction video before operating. Failure to do so could cause machine or property damage or bodily injury.

- Inspect area to be removed for any possible obstruction on floor or defects in carpet (Floor outlets, seams, posts, etc.).
- Remove all debris from carpet area that machine will be anchored to. Keep pin base clear of obstructions (Sweep with broom or vacuum).
- Set machine down onto gripper strip.
- The Powered Carpet Puller can only be anchored to a carpeted surface. The machine can not be used on a smooth surface like concrete, wood, tile or ceramic.
- Remove two screen pins connected to frame and screen (See Figure F).
- Fold screen up and replace screen pins on both sides of lower screen (See Figure G).
- Use a #12-3 grounded or heavier electric cord. Cord should not be over 50 feet.
- Inspect machine and all components before using. See Machine Inspection on page 11.



WARNING: NEVER USE MACHINE WITH DAMAGED GRIPPER STRIPS, ROPE, PULLEY, PULL BAR OR SWITCH. FAILURE TO DO SO COULD CAUSE PROPERTY DAMAGE OR BODILY INJURY.

Machine Operation

SET UP (CONT.)

- Do not allow anyone to use this equipment if they are not properly trained.
- Create a safe working environment. Block off work area to keep anyone from entering area you are working in.
- NEVER operate machine without safety screens in place. Failure to do so could cause bodily injury.

MACHINE INSPECTION

Inspect machine and all components before each use.

- Make certain protective screens are in place before operating (See Figure H). Failure to do so could cause property damage or bodily injury.
- Rope guard is in place: Guard should be in the down position to cover rope and drive shaft (See Figure I). Failure to do so could cause bodily injury resulting in loss of limbs. Do not defeat guard.
- Extension Cord: A #12-3 grounded or heavier electric cord is required. Cord should not be over 50 ft. Inspect cord to ensure that it is in good condition.
- Pull Bar: Inspect weld points making sure they are secure. Inspect clamps to ensure they are not bent or damaged.
- Pulley: Inspect for loose or damaged parts on the pulley wheel, pulley housing, pulley hook and pin.
- Rope: Inspect rope for cuts or fraying. Replace frayed or damaged rope with National stock #71-P33. Make sure rope hook is fastened correctly to rope. Do not tie knots in rope.
- Gripper Strips: Keep pins clean and free from debris. Replace damaged pins with new Gripper Strips, National stock #71-P7. Clean dirty pin strips with a stiff wire brush. Brush in direction of pin angle. Failure to keep pins clear of debris could cause the machine to slip during operation causing property damage or bodily injury.
- Switches and Wiring: Inspect wiring for cuts or damage and switches to ensure they are in good working condition. Switches must return to the off position when released.
- Be sure fill plug is installed on gear unit.
- Motor should not be run without a fan cover in place. Never set machine on power cord.
- Do not run the Powered Carpet Puller with damaged or missing parts.
- Keep labels and manual readable. If labels need replacing, contact National for a replacement.
- Do not modify or alter the Powered Carpet Puller or components in any way. Doing so could cause damage to machine and/or bodily injury.
- Pulley should be inspected before each use. Loose or damaged parts should be replaced immediately. Failure to do so could cause equipment damage or serious injury.
- Rope should be inspected. Worn or cut rope should be replaced with National's Replacement Rope stock #71-P33.

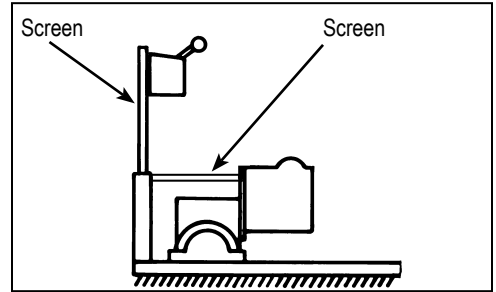

FIG. H

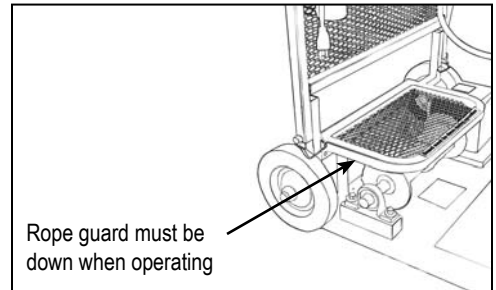

FIG. I



WARNING: FAILURE TO INSPECT MACHINE COMPONENTS COULD CAUSE PROPERTY DAMAGE OR BODILY INJURY.

Machine Operation

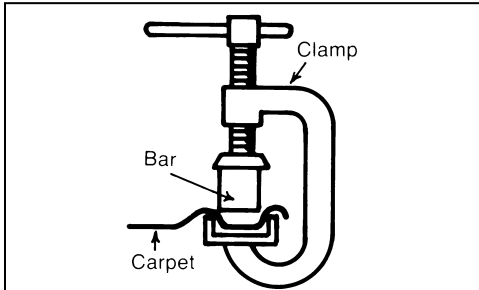

FIG. J

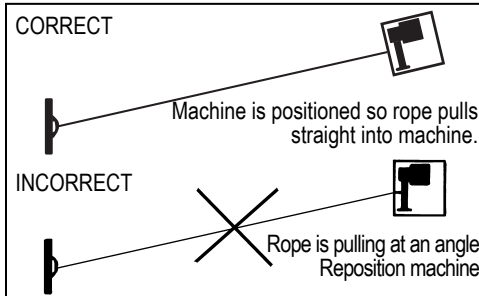

FIG. K







FIG. L



FIG. M



FIG. N

- 
WARNING: NEVER ATTEMPT TO GUIDE ROPE BY HAND ONTO SHAFT WHILE UNDER POWER. OPERATOR COULD BECOME ENTANGLED IN WINDING SHAFT CAUSING SERIOUS INJURY.
- 
WARNING: NEVER TOUCH ROPE OR WINDING SHAFT WHILE OPERATING. DOING SO COULD CAUSE BODILY INJURY.
- 
WARNING: NEVER STAND IN FRONT OR NEXT TO PULL BAR OR TRY TO PULL ON IT WHEN ROPE HAS TENSION ON IT. DOING SO COULD CAUSE SERIOUS BODILY INJURY.
- 
WARNING: NEVER TRY TO OPERATE MACHINE UNATTENDED. DO NOT ALTER SWITCHES OR GUARDS. DO NOT DEFEAT A SAFETY DEVICE.

GENERAL OPERATION

Read instruction manual and view enclosed DVD instruction video before operating. Do not allow anyone to use this equipment if they are not properly trained.

- Inspect area to be removed for any possible obstruction on floor, defects in carpet, cross seams, floor outlets, columns or posts. Failure to do so could cause property damage or bodily injury.
- Remove all debris from carpet area that machine will be anchored to. Keep pin base clear of obstructions. Clear/clean if obstructed. Dirty, damaged or missing pin strips could cause machine to slip.
- Score carpet in 6 ft. widths or narrower if needed.
- Carpet should be pulled in the length direction whenever possible. Observe caution when pulling cross breadth. Carpet is the weakest, especially in woven or axminster construction, when pulling cross breadth. Watch for cross seams. If there is a small piece of carpet attached to the pull bar and the pull bar meets a cross seam, the pull bar will jump forward rapidly.
- Determine where the tear-out will begin. To hook the pull bar up properly, loosen the carpet approximately 12 to 18 inches from the wall. (The #99 Cobra Clamp is an easy way to get ahold of carpet to pull away from the wall). Attach pull bar to loosened carpet. Make certain enough carpet is loosened so the carpet goes all the way through the channel bar, reaching out the other side (all 3 sides) (See Figure A). Insert bar and tighten "C" clamps. Make sure "C" clamps are tightened very tightly and channel bar fits flatly into channel of clamping bar with carpet on all three sides of the bar. (See Figure J). Failure to do so could cause bar to disengage carpet prematurely.
- Move machine into place making sure rope will pull straight into the machine. If rope is pulling at an angle (See Figure K), stop machine. Release pressure on rope. Using front screen to lift base (See Figure L), reposition machine for a straight pull.
- Release drive shaft from pin to extend rope out to pull bar quickly.

Machine Operation

GENERAL OPERATION (CONTINUED)

- Hook rope to pull bar. Either hook rope onto pull bar (See Figure M) or hook pulley onto pull bar and insert rope hook through pulley attaching hook to rope (See Figure N). See Figure Q for double pull instructions.
- With power off, take up slack quickly by hand. Reengage drive shaft to pin.
- Lower rope guard safety screen over shaft before operation under power.
- Rope feeds in from the bottom of the drive shaft (See Figure O).
- Single pull will remove approximately 30 feet per minute. Double pull will remove approximately 15 feet per minute.
- Rope guard must be down before operating machine (See Figure P).
- If machine seems to bog down when pulling on single pull, immediately shut off machine and go to a double pull (See Figure Q). Double pull requires the use of a pulley attached to the pull bar. Loop rope through pulley and attach rope hook to securing point on puller base (See Figure R).
- Be extremely careful that pull bar is always free from obstructions such as posts or other solid objects. If you should hit an obstruction, release tension on rope before adjusting pull bar.
- Rope is usually hooked into the center “hook up” on the pull bar. Hooking to the right or left “shift hook” on pull bar will keep pull bar at an angle to stay clear of a wall or object.

WARNING: NEVER STAND IN FRONT OR NEXT TO PULL BAR OR TRY TO PULL ON IT WHEN ROPE HAS TENSION ON IT. DOING SO COULD CAUSE SERIOUS BODILY INJURY.

- Make certain that no one is standing between the pull bar and the machine (See Figure R).
- If you need to make any adjustments on pull bar, be sure all pressure is released on pull rope.
- If strength of carpet does not allow 6 ft. width to be pulled without breaking the carpet or stalling the machine, cut carpet into smaller widths or convert from single to double pull mode (See Figure Q).
- Stand behind the screen, on the bottom plate when operating the machine.

WARNING: NEVER TRY TO OPERATE MACHINE UNATTENDED. DO NOT ALTER SWITCHES OR GUARDS. DO NOT DEFEAT A SAFETY DEVICE.

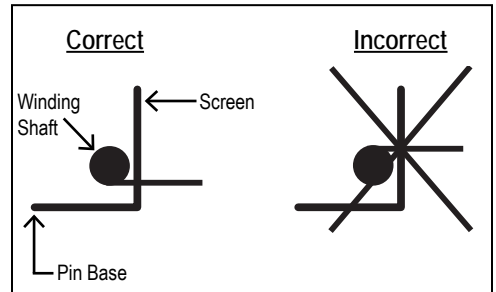

FIG. O

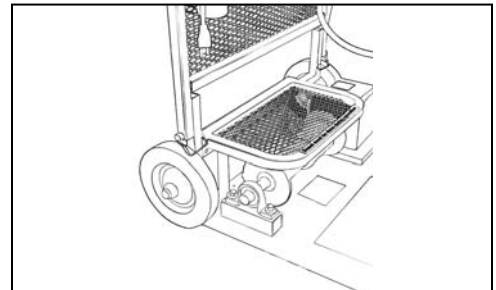

FIG. P

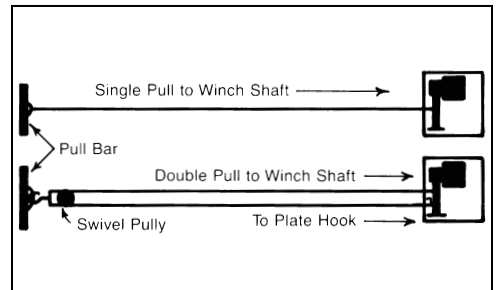

FIG. Q

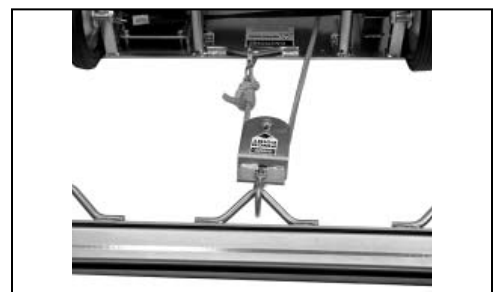

FIG. R

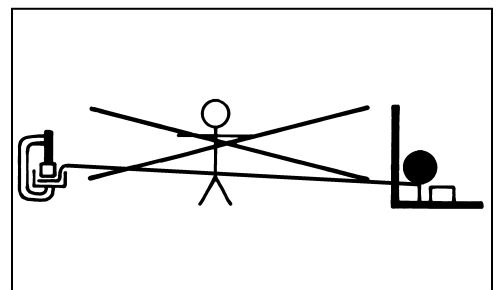

FIG. S

Machine Operation

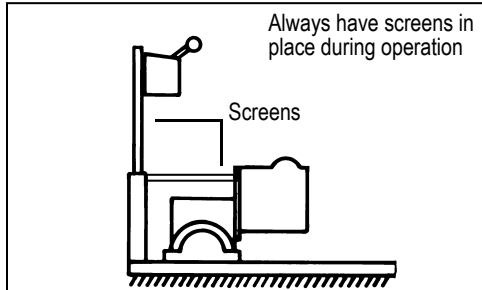

FIG. T

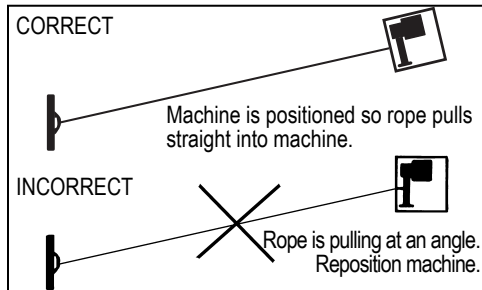

FIG. U



FIG. V

- Make certain protective screens are in place before operating (See Figure T).
- Operate using control box, select speed and pull direction. Press Start button to begin pulling and red Stop button to disengage.
- Always release tension on rope and pull bar when machine is stopped.
- Run pull bar up to machine but NOT into machine.



CAUTION: SWITCHES MUST COME TO NEUTRAL POSITION AND SPOOL/ ROPE COME TO STOP BEFORE REVERSE DRIVE WILL ENGAGE



CAUTION: NEVER RAPIDLY MOVE THE SWITCH FROM FORWARD TO REVERSE. PULLING DIRECTION WILL NOT CHANGE.

- Pull rope should always be at a 90 degree angle to the machine. Always have rope going straight into the machine. Never have machine at an angle where the rope winds sideways on the shaft (See Figure U). This could cause the rope to wind improperly on the shaft and damage the rope.
- To adjust machine base, make sure tension is released from rope and pull bar. Lift base using front screen. Adjust machine (See Figure V) and set back down.
- If you are using an angle pull from one room to another, make sure hallways are blocked off to keep anyone from walking through the pulling path.
- Unplug machine when it is not in use.
- Cover pins with protective Grip Strip cover when machine is not in use
- Always block off work area from other people



UNPLUG THE MACHINE WHEN IT IS NOT IN USE

Machine Operation

ROPE

- If rope becomes frayed, it should be cut off or replaced with National stock #71-P33 Replacement Rope. Do not tie rope together. Do not use any other type of rope that does not meet National specifications (less than 6 to 8% stretch, 13,900 pound tensile strength). Failure to do so could cause property damage or bodily injury.



WARNING: DO NOT USE CABLE. DOING SO COULD CAUSE PROPERTY DAMAGE OR BODILY INJURY.

- Rope should always pull straight into the machine never at an angle.
- Rope feeds in from the bottom of the drive shaft.
- Never have machine at an angle where the rope winds sideways on the shaft. This could cause the rope to wind improperly on the shaft and damage the rope.
- Do not modify or alter rope, switches or guards in any way.
- Make sure hook is securely tied to rope. See instruction video for demonstration of the correct knot.



CAUTION: THE IMPROPER USE OF ROPE IS DANGEROUS, RESULTING IN BODILY INJURY OR DEATH.



WARNING: ROPE WILL FAIL IF WORN, DAMAGED, ABUSED, OVERLOADED OR NOT PROPERLY MAINTAINED.



WARNING: DO NOT STAND WITHIN RECOIL (SNAPBACK) AREA, UNLESS PROTECTED BY SCREEN. FAILURE TO DO SO COULD CAUSE SERIOUS BODILY INJURY OR DEATH.

- The user is responsible to determine the suitability of the rope for specific applications.
- Use only rope in good condition, without cuts or frays.
- Know the working load limit (WLL) of your rope.
- Do not use over rough surfaces without chafe protection. Doing so could cause damage to rope.
- Do not bend around unprotected, sharp corners. Doing so could cause damage to rope.
- Use sheaves (pulleys) that are in good condition.



WARNING: DO NOT USE ANY OTHER TYPE OF ROPE THAT DOES NOT MEET NATIONALS SPECIFICATIONS. OTHER TYPES OF ROPE WHICH MAY HAVE THE PROPER WLL, GENERALLY HAVE A HIGH ELONGATION OR STRETCH FACTOR, MAKING MACHINE POTENTIALLY DANGEROUS FROM ROPE SNAP BACK RESULTING IN BODILY INJURY OR DEATH. ONLY USE NATIONAL #71-P33 REPLACEMENT ROPE FOR SAFE OPERATION. FAILURE TO DO SO COULD CAUSE PROPERTY DAMAGE OR BODILY INJURY. NEVER USE CABLE.

Machine Operation

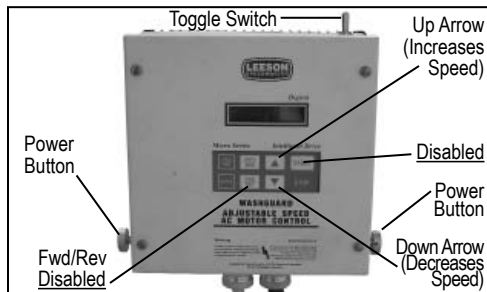

FIG. W



FIG. X



FIG. Y

MACHINE START UP PROCEDURE

TO RUN MACHINE

1. Connect machine to power source.
2. Select direction with toggle (Figure W). Press and hold both power buttons (one on each side of controller).

Note: Machine is programmed with a slow start.

Change Direction: Select with toggle switch

Change Speed: Up Arrow = Faster
Down Arrow = Slower

Change Display Units: Enter Button

- Once power is applied to drive (This will usually mean the unit is plugged in) the display will appear similar to this: "Stop/Run > xx.xx"
- The max frequency is pre-set to 60 hz. The exception: last operating speed is displayed in HZ.
- Press both Start buttons - Motor will start to turn. Full speed will be achieved in 3 seconds.
- If motor is running wrong direction - Change toggle
- To change speed - Press & hold the Up Arrow to increase speed (up to a factory preset maximum). Press & hold Down Arrow button to decrease speed. Speed is adjustable from 60 HZ to 30 HZ and displayed on screen.
- Stop - Release power buttons

CONTROLLER FAULT AND CIRCUIT OVERLOAD

If puller is faulting or circuits are blowing, the machine could be overloaded. This could be due to individual jobsite power sources and/or variances in jobsite floor surfaces. Always monitor load percent and make alterations to machine accordingly. Do not run load over 100%.

Always be aware of the load percent while running the machine. To display the load percent, press the Enter Button on the controller twice (Figure X).

If display reads over 100 percent (Figure X), the machine is overloaded.

To take load off the machine, follow one or more of the following:

1. Slow the speed of the machine down by holding the Arrow Down Button (Figure X).
2. If machine is in single pull mode, convert to Double Pull Mode.



WARNING: ONCE MACHINE IS RUNNING, KEEP IT ON "LOAD MODE". ALWAYS BE AWARE IF THIS GOES OVER 100%.

Machine Maintenance



FIG. W



WARNING: MAKE CERTAIN THAT THE POWER SUPPLY IS DISCONNECTED BEFORE ATTEMPTING TO SERVICE OR REMOVE ANY COMPONENTS. FAILURE TO DO SO COULD CAUSE ELECTRIC SHOCK.

PREVENTIVE MAINTENANCE

1. Inspect for damage on all exposed power cords, rope, switches and guards. Worn or broken cords and switches could result in electrical shock.
2. Oil level in gear box should be checked once a year. Remove level screw on side of gearbox, add if needed (Mobil SHC 634).
3. Pull rope should be replaced when excessive wear (reduction in diameter), frays or cuts into your rope are visible. Use #71-P33 Replacement Rope.
4. During operation, make sure guard stays down over rope. Do not defeat guard. Failure to do so could cause bodily injury.
5. Drive shaft and pillow block bearing should be greased for free shaft movement to engage and disengage grease when needed.
6. Pulley should be examined prior to each use for free movement of pulley wheel and to ensure pulley frame and hook are free from damage.
7. Always read instruction manual and view instruction video before operating Powered Carpet Puller for the first time.

CLEANING

Properly selected and installed electric motors are capable of operating for long periods with minimal maintenance. Periodically clean dirt accumulations from open-type motors, especially in and around vent openings, preferably by vacuuming (avoids embedding dirt in windows). At the same time, check that electrical connections are tight.

ROPE

Replace rope if frays or cuts are noticeable.

To Remove Rope: Lift guard. Release drive shaft pin. Pull rope off of drive shaft. Cut knot off at the end of rope to remove.

To Install Rope: Insert rope through hole in drive shaft on the side winder guide. Tie a knot on end of rope to secure. Take up slack quickly by hand, then reengage drive shaft pin. Release guard down into place. Turn switch to forward to wind rope onto drive shaft.

Rope Hook: Secure rope hook to end of rope with knot demonstrated on instruction video (See Figure W).

PULL BAR

Internal clamping bar could build up with residue. Remove bar. Wearing gloves, scrape off residue with a razor scraper or wipe off with a safety solvent. Inspect clamp for proper condition. Make sure "C" clamps are not bent and are working properly.

Machine Maintenance

GRIPPER STRIPS

Use protective cover over gripper strips when the machine is being transported or not in use. Keep gripper pins free of debris.



CAUTION: NEVER USE MACHINE WITH DAMAGED OR CLOGGED GRIPPER STRIPS. CLOGGED GRIPPER STRIPS WILL NOT ALLOW MACHINE TO STAY SECURED WHICH COULD CAUSE DAMAGE TO MACHINE, PROPERTY DAMAGE OR BODILY INJURY



FIG. X

Care: Wearing gloves, use a wire brush. Brush over pins in a downward motion, (from back of machine to front of machine) removing debris caught in pins (See Figure X). Use a long shank screwdriver to pry out debris that is embedded into the pins. Not wearing gloves could cause bodily injury.

REPLACING GRIPPER STRIPS

Remove six phillips head screws. Take off damaged gripper strip and replace with a new gripper strip. Gripper strip pins are angled. The angle faces towards the front of the machine (See Figure Y). Repeat with (4) four remaining gripper strips.

Screw replacement - See Figure Z.

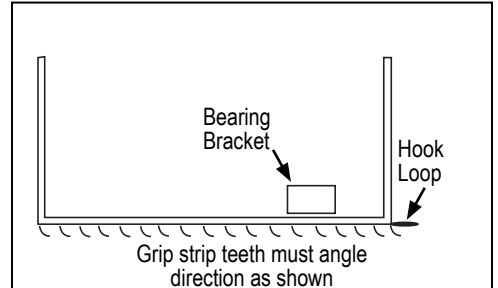

FIG. Y

LUBRICATION

Figure AA illustrates the correct locations for the oil fill plug, the oil level plug, and the oil drain plug on the reducer. Plugs may vary in location on the sides of the reducer.

For new reducers, change the oil 120 hours after the reducer starts operating (based on 8 hours per day operation). After the first change, change oil every 2,000 operating hours, or every six months, whichever occurs first.

Use Mobil SHC® 634 gear lubricant or a similar synthetic gear oil. ISO viscosity grade 460. Available from National, stock #1450-40, 1 quart.

ADDING OIL

Remove both the fill plug and oil level plug. Place oil in the fill plug hole. Keep adding oil in until it starts to come out of the oil level plug hole. Replace plugs.

CHANGING OIL

Drain oil out of unit by removing drain plug. Replace drain plug. Remove both the fill plug and the oil level plug. Place oil in the fill plug hole. Keep adding oil in until it starts to come out of the oil level plug hole and repeat.

CHANGING THE OUTPUT OIL SEAL

Remove the rope shaft and the gear reducer from the unit. Place some form of support, (2 x 4 etc.), under the gear reducer shaft to keep it from bending. Drive out the gear reducer shaft pin. Pick out the old seal. Clean out the area where the old seal was. Install the new seal, carefully press it in. Install drive pin again. Put some "Locktite" around the middle of the pin and carefully press into the shaft. If you find that the pin is loose, you may need a new pin. Depending on how much oil leaked, check to see if your unit needs more oil. Add oil if needed. Install the rope shaft.

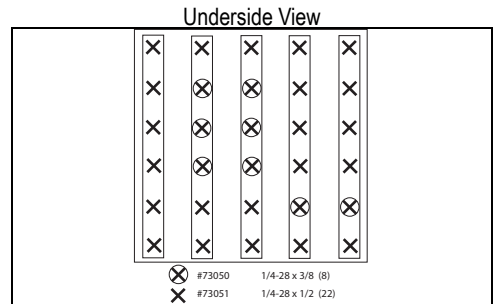

FIG. Z

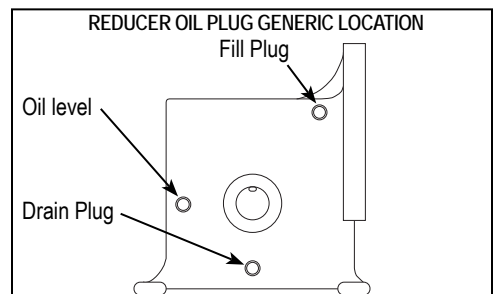

FIG. AA

Troubleshooting Guide

Problem	Cause	Solution
Unit fails to operate	<ol style="list-style-type: none"> 1. Blown fuse or open circuit breaker 2. No power 3. Defective motor 4. Excessive load 	<ol style="list-style-type: none"> 1. Replace fuse or reset circuit breaker 2. Check power source, 12 gauge wire cord must be used not over 50 ft. 3. Repair or replace 4. Convert to double pull (reduce load)
Input motor runs, but speed reducer output shaft doesn't turn	<ol style="list-style-type: none"> 1. No input pin on shaft 2. Defective gear(s) 	<ol style="list-style-type: none"> 1. Install pin (see installation) 2. Check and replace if necessary
Intermittent rotation of output shafts	<ol style="list-style-type: none"> 1. Poor electrical connection 2. Damaged gear assembly, possibly caused by shock load 	<ol style="list-style-type: none"> 1. Check connection 2. Replace gear and, if possible, avoid shock load
Excessive noise	<ol style="list-style-type: none"> 1. Bearings worn 2. Shaft misaligned 3. Weight overload, exceeds ratings and causes bearing wear 4. Insufficient lubrication 5. Dented fan cover 	<ol style="list-style-type: none"> 1. Replace 2. Adjust shaft 3. Correct load and/or replace bearing 4. Check oil level 5. Replace fan cover
Oil leak	<ol style="list-style-type: none"> 1. Fill plug not installed 2. Gasket broken or not sealed 3. Damaged or worn seal 4. Too much oil 	<ol style="list-style-type: none"> 1. Install fill plug 2. Replace or reseal gasket 3. Replace seal 4. Check oil level
Machine moves while in use	<ol style="list-style-type: none"> 1. Gripper Strips 	<ol style="list-style-type: none"> 1. Clean or replace gripper strips 2. Remove debris from floor surface before setting machine in place to pull
Rope doesn't wind on shaft correctly	<ol style="list-style-type: none"> 1. Pulling at an angle 	<ol style="list-style-type: none"> 1. Release pressure on rope. Using screen, position machine for a straight pull.

If machine seems to bog down when pulling on single pull, immediately shut off machine, release pressure and go to a double pull. Double pull requires the use of a pulley attached to the pull bar. Loop rope through pulley and attach hook to puller base (See Figure BB).

If strength of carpet does not allow 6 ft. width to be pulled without breaking, cut carpet into smaller widths.

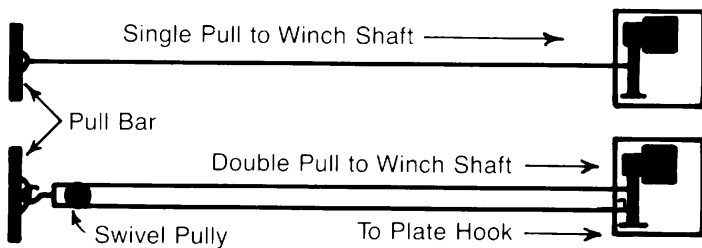

FIG. BB

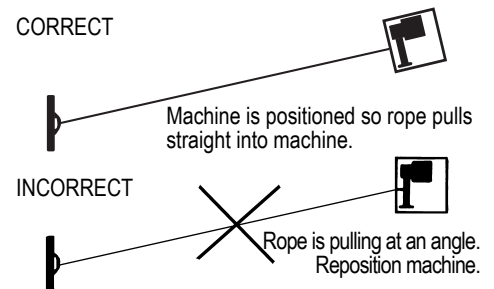

FIG. CC

Troubleshooting Guide

Problem	Cause	Solution
Overload Run	Motor overloaded	Remove weight, slow machine or change tooling.
Low Volts Acceleration	Line volts too low at start	a. Check cord length and gauge. b. Check power source.
Low Volts Run	Line volts too low	c. Check cord length and gauge. d. Check power source.
High Voltage	Line volts too high	Wired wrong or to improper supply.
Power Sag	Erratic line volts	Check power supply, cord or for loose connection.
External Acceleration	Kill switch off	Check kill switch - it is either off or malfunctioning.
External Run	Kill switch off	Check kill switch - it is either off or malfunctioning.

Complete Parts List

PART#	DESCRIPTION	QTY	PART#	DESCRIPTION	QTY
1	71-1 PULL BAR	12"	50	1451-9 BEARING, BALL INPUT (#204)	1
2	71-2 PULL BAR	46"	51	1451-10 RING RETAINER - EXTERNAL	1
3	71-2A CLAMP BAR INSERT ONLY	46"	52	1451-11 BEARING, OUTPUT TAPPED ROLLER	1
4	71-3 PULL BAR	7'	53	1451-12 SPACER, SOLID OUTPUT (2.06)	1
5	71-20 ROPE GUARD	1	54	1451-13 GEAR, SOLID OUTPUT (2.06)	1
6	71-P8 REPLACEMENT GRIPPER STRIP	1	55	1451-14 O-RING, AS568A-043	1
7	71-P8S GRIPPER STRIP SPACER	5	56	1451-15 SHIM, OUTPUT	1
8	71-P10 CASTER WHEEL	1	57	1451-19 GEAR REDUCER SEAL, OIL OUTPUT (NATIONAL)	1
9	71-P15 ROPE HOOK	1	58	1451-20 FLANGE, QUILL (56C/140TC)	1
10	71-P16 PULLEY COMPLETE	1	59	1451-21 SEAL, OIL, INPUT FLANGE	1
11	71-P16-1 PULLEY WHEEL & BUSHING ONLY	1	60	1451-30 SOLID OUTPUT ASSEMBLY REPLACEMENT	1
12	71-P16-1A PULLEY WHEEL ONLY	1	61	62180 MOTOR FAN COVER	1
13	71-P16A PULLEY BUSHING ONLY	1	62	62181 MOTOR FAN	1
14	71-P16B PULLEY BODY ONLY	1	63	62182 CAPACITOR COVER	1
15	71-P16-2 PULLEY HOOK ONLY	1	64	62183 CAPACITOR	1
16	71-P17 DRIVE SHAFT	1	65	62190 CONDUIT BOX ONLY	1
17	71-P24 SWITCH ONLY	2	66	62191 CONDUIT BOX COVER ONLY	1
18	71-P24A SWITCH WITH CORD ONLY (LEFT)	1	67	62192 CONDUIT BOX COVER SCREW ONLY	4
19	71-P26D SWITCH TO SWITCH WIRE ONLY	1	68	70602 INSTRUCTION TUBE	1
20	71-P27 DOUBLE SWITCHES WIRED COMPLETE (SET)	1	69	70603 INSTRUCTION TUBE CAP	1
21	71-P27-1 REVERSING DRUM SWITCH WITH MOTOR		70	71112 PILLOW BLOCK BEARING	1
	CORD ONLY (RIGHT)	1	71	72361-72 1.5 HP MOTOR	1
22	71-P27-1A MOTOR CORD ONLY	1	72	72803 1/2 STRAIGHT CABLE CONNECTOR	1
23	71-P27-2 ON/OFF SWITCH WITH POWER CORD ONLY	1	73	72804 1/2 STRAIGHT CORD CONNECTOR	1
24	71-P28 LARGE WIRE CLAMP	1	74	73007 1/4 FLAT WASHER	4
25	71-P29 METAL GREENFIELD	1	75	73025 1/4 RIVET	5
26	71-P32 PROTECTIVE GRIP STRIP COVER & STRAPS	1	76	73031 1/4 X 1 FENDER WASHER (2-SCREEN, 1-CORDS)	1
27	71-P33 ROPE	50'	77	73050 1/4-28 X 3/8 BUTTON HEAD CAP SCREW	8
28	71-P33-1 ROPE SPOOL	600'	78	73051 1/4-28 X 1/2 BUTTON HEAD CAP SCREW	22
29	71-P56 REVERSING DRUM SWITCH WITH MOTOR	1	79	73201 3/8-16 X 1 HEXHEAD BOLT	4
	CORD & FEMALE PLUG (RIGHT)	1	80	73203 3/8 FLAT WASHER	6
30	71-P58 MOTOR CORD WITH MALE PLUG (5 PRONG)	1	81	73204 3/8 LOCK WASHER	4
31	71-S2 SCREEN	1	82	73205 3/8-16 X 3/4 HEXHEAD BOLT	4
32	71-VI INSTRUCTION VIDEO	1	83	73206 3/8-16 X 1 1/4 HEXHEAD BOLT	2
33	500-12 WIRE WITH MOLDED PLUG ONLY	1	84	73210 3/8 INT/EXT LOCK WASHER	1
34	500-29 WHEEL	1	85	73215 3/8 EXTERNAL LOCK WASHER	4
35	1450-2 INPUT OIL SEAL	1	86	73241 3/8-24 X 1 1/8 HEXHEAD BOLT	4
36	1450-13 BOX SEAL (DAYTON), SHAFT END (EXTERNAL)	1	87	73260 3/8 90° CABLE CONNECTOR	2
37	1450-27 GEAR BOX SEAL (DAYTON), INTERNAL		88	73261 3/8 STRAIGHT CABLE CONNECTOR	3
	SHAFT END	1	89	73322 5/16-18 NYLON LOCK NUT	2
38	1450-28 DRIVE SHAFT PIN ONLY	1	90	73327 5/16-18 X 2 1/2 HEXHEAD BOLT	2
39	1450-40 GEAR OIL, 1 QT.	1	91	73330 5/16 X 2 PIN	2
40	1450-50 SPACER PLATE FOR GEAR	1	92	73409 1/2-13 X 2 1/2 HEXHEAD CAP SCREW	1
41	1451 GEAR REDUCER WITH PLATE & PIN	1	93	73420 1/2-13 HEX NUT	1
42	1451-1 GEAR HOUSING	1	94	73525 5/8-11 NYLON LOCK NUT	1
43	1451-2 PLUG, PIPE HEX SOCKET	1	95	73526 5/8 FLAT WASHER ONLY	4
44	1451-3 PLUG, POPPET VENT .25-18 NPT	1	96	74406 10-32 X 3/8 PHILLIPS HEAD MACHINE SCREW	4
45	1451-4 PLATE, OIL SPLASH GUARD	1	97	74407 10-32 X 1/2 MACHINE SCREW SCREW	1
46	1451-5 COVER, INPUT BLIND	1	98	74425 10-32 KEPS NUT	5
47	1451-6 O-RING, AS568A-043	1	99	74426 10-32 HEX NUT	1
48	1451-7 SCREW, HEX HEAD CAP	1			
49	1451-8 SHAFT, INPUT QUILL (2.06 C.D)	1			

Parts List and Diagrams

SCREEN



PART#	DESCRIPTION	QTY
1 71-S2	SCREEN	1
2 73007	1/4 FLAT WASHER	4
3 73014	1/4-20 X 1 1/2 HEXHEAD BOLT	4
4 74406	10-32X3/8 PHILLIPS HEAD MACHINE SCREW	4

PULLEY

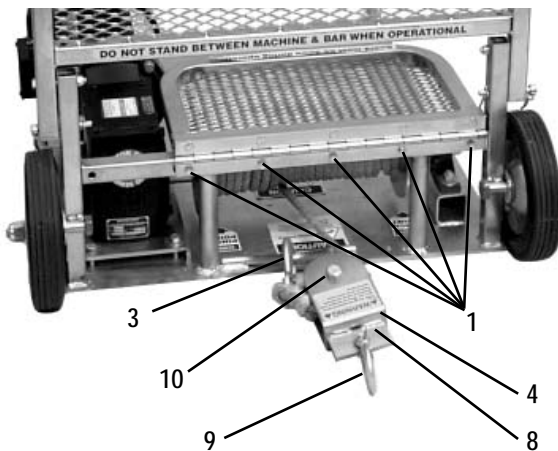

PART#	DESCRIPTION	QTY
1 71-20A	1/4 ROPE GUARD RIVET	5
2 71-P10	CASTER WHEEL	1
3 71-P15	ROPE HOOK	1
4 71-P16	PULLEY COMPLETE	1
5 71-P16-1	PULLY WHEEL & BUSHING ONLY	1
6 71-P16-1A	PULLY WHEEL ONLY	1
7 71-P16A	PULLY BUSHING ONLY	1
8 71-P16B	PULLEY BODY ONLY	1
9 71-P16-2	PULLEY HOOK ONLY	1
10 73409	1/2-13 X 2 1/2 HEXHEAD CAP SCREW	1

PULL BAR

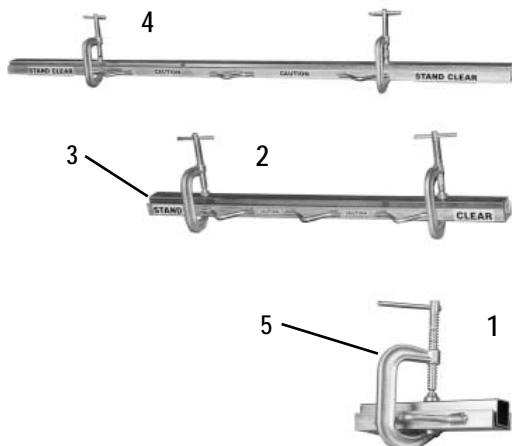

PART#	DESCRIPTION	QTY
1 71-1	PULL BAR 1'	1
2 71-2	PULL BAR 46"	1
3 71-2A	46" CLAMP BAR INSERT ONLY	1
4 71-3	PULL BAR 7'	1
5 71-C	"C" CLAMP ONLY	1

Parts List and Diagrams

PART#	DESCRIPTION	QTY
1	500-29 WHEEL (EACH)	1
2	1450-13 BOX SEAL (DAYTON), SHAFT END (EXTERNAL)	1
3	1450-27 GEAR BOX SEAL (DAYTON), SHAFT END	1
4	1450-28 DRIVE SHAFT PIN ONLY	1
5	1451 GEAR REDUCER WITH PLATE & PIN	1
6	1451-19 GEAR REDUCER SEAL (NATIONAL)	1
7	73201 3/8-16 X 1 HEXHEAD BOLT	4
8	73204 3/8 LOCK WASHER	4
9	73215 3/8 EXTERNAL LOCK WASHER	4
10	73241 3/8-24 X 1 1/4 HEXHEAD BOLT	4
11	73322 5/16-18 NYLON LOCK NUT	2
12	73327 5/16 X 18 X 2 1/2 HEXHEAD BOLT	2
13	73330 5/16 X 2 PIN	2
14	73525 5/8-11 NYLON LOCK NUT	1

WHEEL & GEAR REDUCER

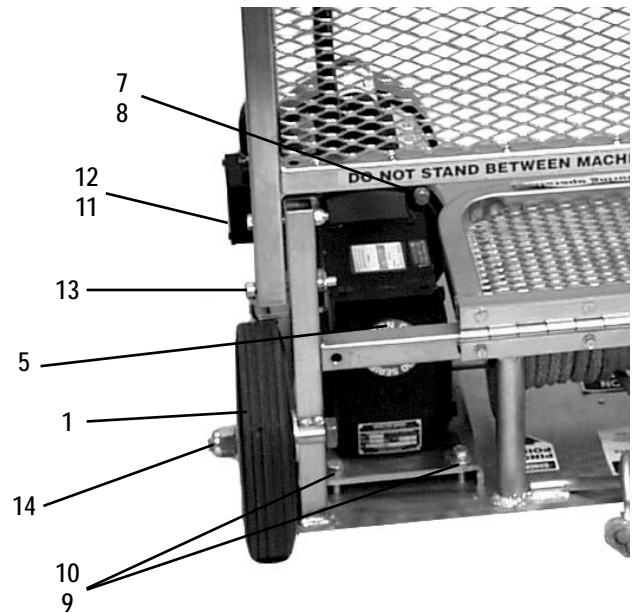

PART#	DESCRIPTION	QTY	PIN
1	73330 5/16 X 2 PIN	2	

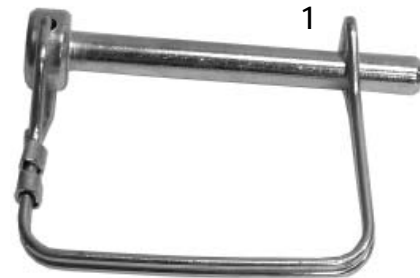

Parts List and Diagrams

GEAR REDUCER

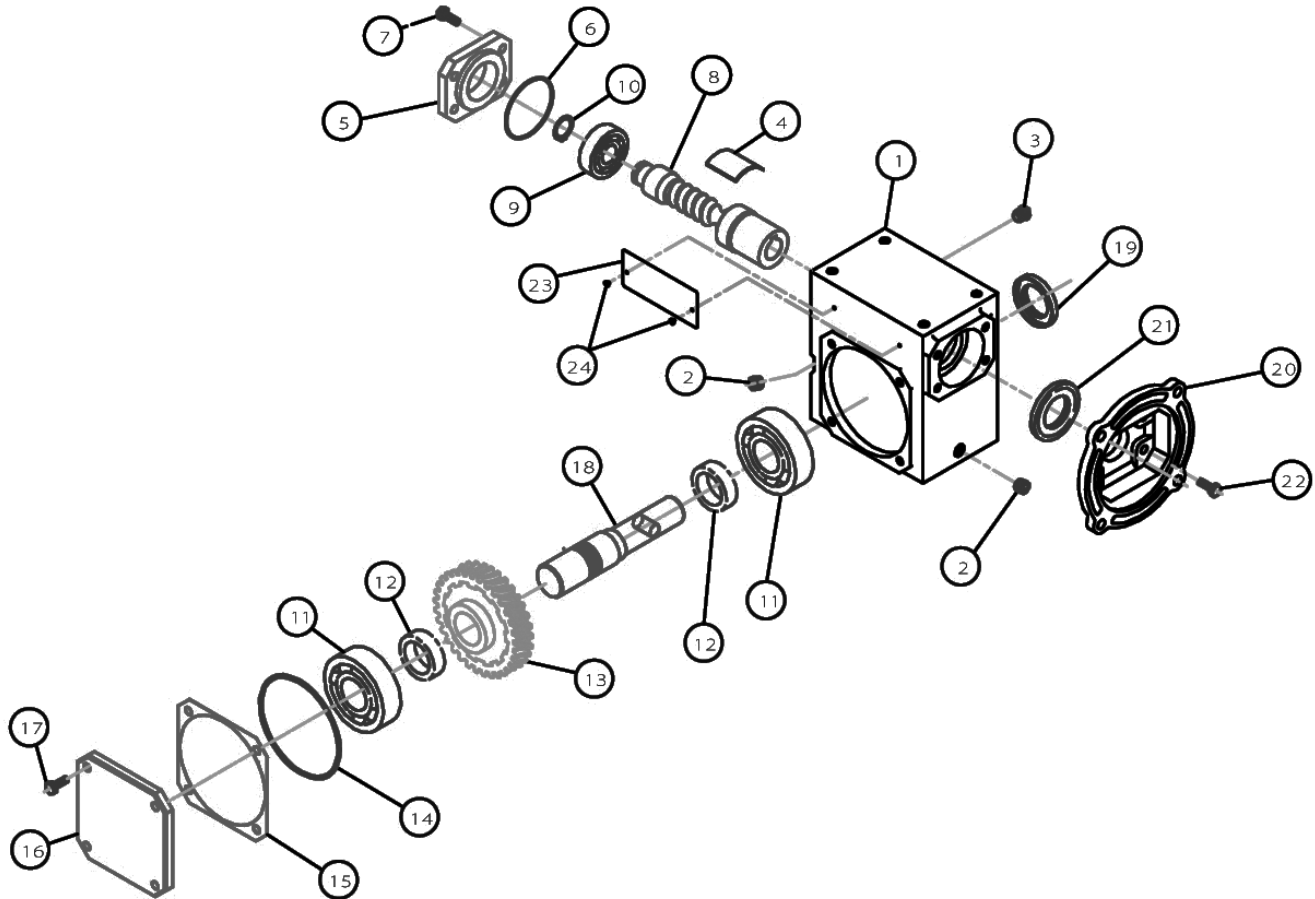

PART#	DESCRIPTION	QTY	PART#	DESCRIPTION	QTY
1	1450-28	DRIVE SHAFT PIN	13	1451-9	BEARING, BALL INPUT (#204)
2	1450-40	GEAR OIL, 1 QT.	14	1451-10	RING, RETAINER - EXTERNAL
3	1450-50	SPACER PLATE FOR GEAR	15	1451-11	BEARING, OUTPUT TAPPED ROLLER
4	1451	GEAR REDUCER W/PLATE & PIN	16	1451-12	SPACER, SOLID OUTPUT, (2.06)
5	1451-1	GEAR HOUSING	17	1451-13	GEAR, SOLID OUTPUT, (2.06)
6	1451-2	PLUG, PIPE HEX SOCKET	18	1451-14	O-RING, AS568A-043
7	1451-3	PLUG, POPPET VENT .25-18 NPT	19	1451-15	SHIM, OUTPUT
8	1451-4	PLATE, OIL SPLASH GUARD	20	1451-19	SEAL, OIL OUTPUT
9	1451-5	COVER, INPUT BLIND	21	1451-20	FLANGE, QUILL (56C/140TC)
10	1451-6	O-RING, AS568A-031	22	1451-21	SEAL, OIL, INPUT FLANGE
11	1451-7	SCREW, HEX HEAD CAP	23	1451-30	SOLID OUTPUT ASSEMBLY REPLACEMENT
12	1451-8	SHAFT, INPUT QUILL (2.06 C.D.)			

Parts List and Diagrams

PART#	DESCRIPTION	QTY
1	71-P24 SWITCH ONLY (NOT WIRED)	2
2	71-P24A SWITCH WITH CORD ONLY (LEFT)	1
3	71-P27 DOUBLE SWITCHES WIRED COMPLETE	1
4	71-P27-1 REVERSING DRUM SWITCH WITH MOTOR CORD ONLY (RIGHT)	1
5	71-P27-2 ON/OFF SWITCH W POWER CORD ONLY	1

CONTROLLER PARTS



PART#	DESCRIPTION	QTY
1	71-P26D SWITCH TO SWITCH WIRE ONLY	1
2	71-P27-1A MOTOR CORD ONLY	1
3	71-P28 LARGE WIRE CLAMP	1
4	71-P29 METAL GREENFIELD	1
5	500-12 WIRE AND MOLDED PLUG ONLY	1
6	72803 1/2 STRAIGHT CABLE CONNECTOR	1
7	72804 1/2 STRAIGHT CORD CONNECTOR	1
8	73031 1/4 X 1 FENDER WASHER	1
9	73260 3/8 90° CABLE CONNECTOR	2
10	73261 3/8 STRAIGHT CABLE CONNECTOR	3
11	74407 10-32 X 1/2 MACHINE SCREW	1
12	74426 10-32 HEX NUT	1

CORDS



PART#	DESCRIPTION	QTY
1	70602 INSTRUCTION TUBE	1
2	70603 INSTRUCTION TUBE CAP	1

INSTRUCTION TUBE

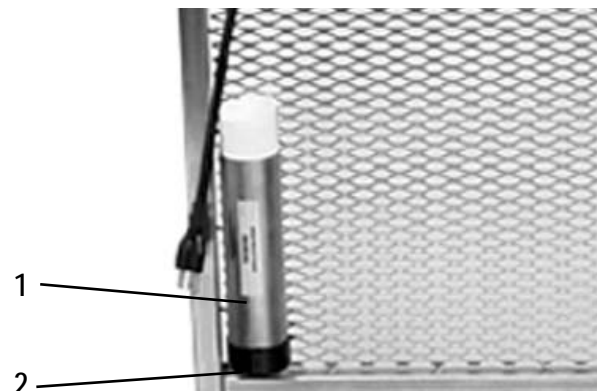

Parts List and Diagrams

ROPE & DRIVE SHAFT

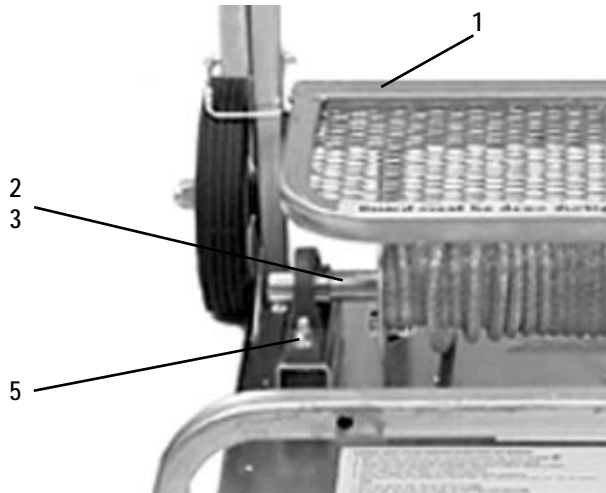

	PART#	DESCRIPTION	QTY
1	71-20	ROPE GUARD	1
2	71-P17	DRIVE SHAFT	1
3	71-P18	PILLOW BLOCK BEARING	1
4	71-P33	50 FT. ROPE	1
5	73210	3/8 INT/EXT LOCK WASHER	2

PILLOW BLOCK BEARING PARTS

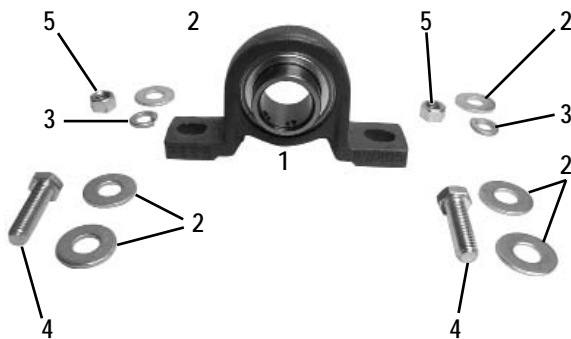

	PART#	DESCRIPTION	QTY
1	71112	1" ID BEARING	1
2	73203	3/8 FLAT WASHER	6
3	73204	3/8 SPLIT LOCK WASHER	4
4	73206	3/8-16 X 1 1/4 HEXHEAD BOLT	2
5	73207	3/8 NYLON LOCK NUT	2

PILLOW BLOCK BEARING PARTS



	PART#	DESCRIPTION	QTY
1	72-21	MOTOR SPACER	1
2	72-20	SHAFT REDUCER	1
3	72361-72	1.5 HP MOTOR	1

Parts List and Diagrams

PART#	DESCRIPTION	QTY
1	71-P8 REPLACEMENT GRIPPER STRIP (5 STRIPS PER BASE)	1
2	71-P8S GRIPPER STRIP SPACER	5
3	71-P32 PROTECTIVE GRIP STRIP COVER & STRAPS	1
4	73051 1/4-28 X 1/2	22
5	73050 1/4-28 X 3/8	8

GRIPPER STRIP

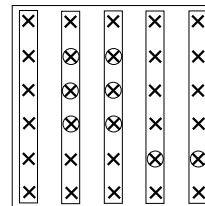
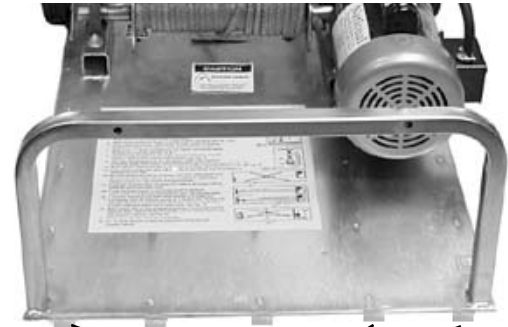

Underside View

Parts List and Diagrams

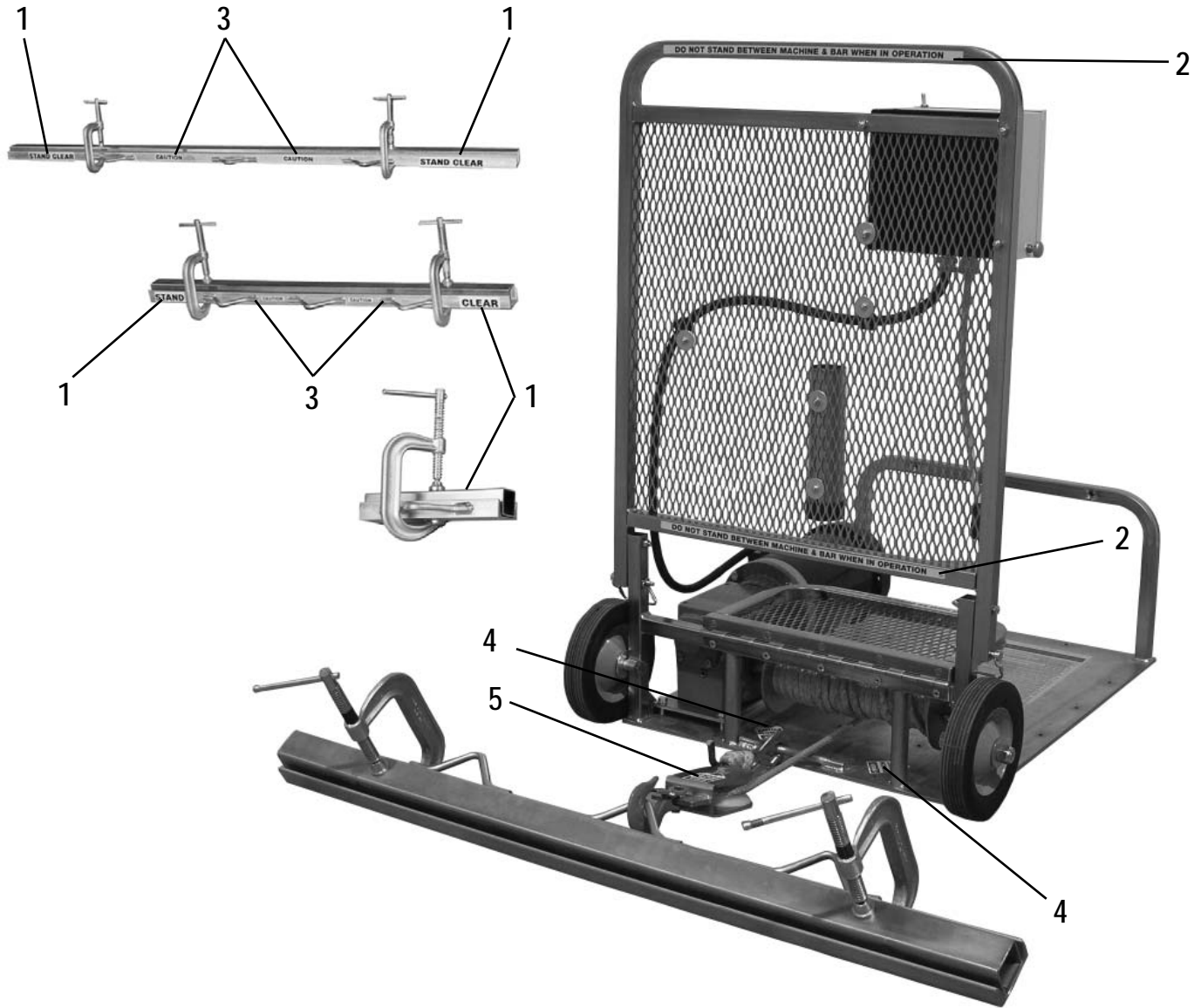

PART#	DESCRIPTION	QTY	PART#	DESCRIPTION	QTY		
1	L08	STAND CLEAR LABEL (PER BAR)	2	4	L106	PINCH POINT LABEL	3
2	L26	DO NOT STAND BETWEEN	3	5	L1000	PULLEY WARNING LABEL	1
3	L66	CAUTION LABEL (PER BAR)	2				

Parts List and Diagrams

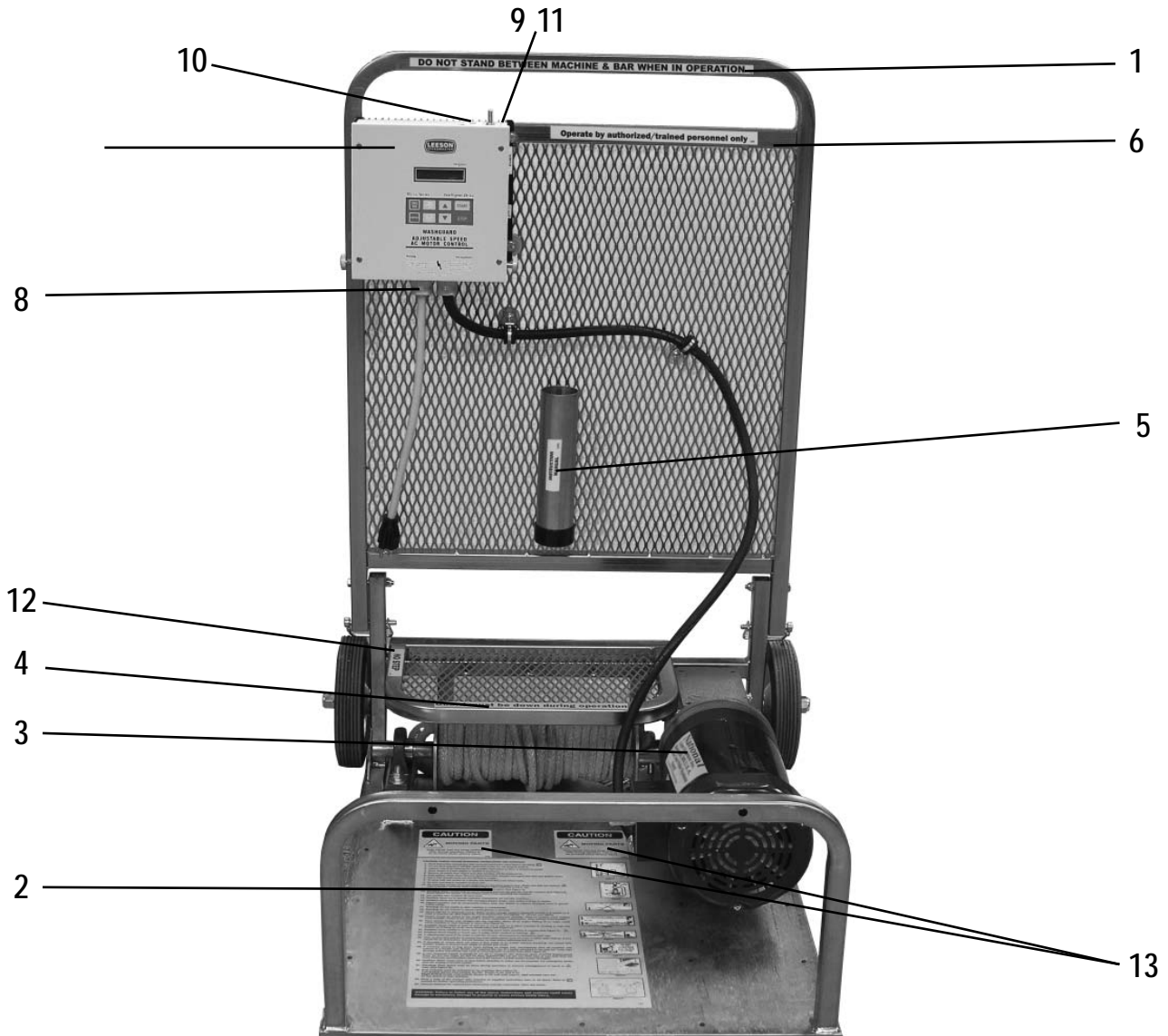

PART#	DESCRIPTION	QTY	PART#	DESCRIPTION	QTY
1	L26 DO NOT STAND BETWEEN	3	8	L95J 110 VOLT LABEL (ON CONTROL BOX)	1
2	L27 OPERATING INSTRUCTIONS LABEL	1	9	L110B OFF LABEL	1
3	L32A STOCK #72 LABEL	1	10	L110C IN LABEL	1
4	L33A GUARD MUST BE DOWN LABEL	1	11	L110D OUT LABEL	1
5	L33C INSTRUCTION MANUAL LABEL	1	12	L135 NO STEP LABEL	1
6	L33D AUTHORIZED PERSONNEL ONLY LABEL	1	13	L33B CAUTION MOVING PARTS LABEL (NOT SHOWN)	2
7	L49 CAUTION CORD LABEL	1			

GUARANTEE

National Flooring Equipment, Inc. (National) warrants to the first consumer/purchaser that this National brand product (72 High Performance Powered Carpet Puller) when shipped in its original container, will be free from defective workmanship and materials and agrees that it will, at its option, either repair the defect or replace the defective product or part thereof at no charge to the purchaser for parts or labor for the period(s) set forth below.

This warranty does not apply to any appearance items of the product, to the additional excluded items set forth below, or to any product, the exterior of which has been damaged or defaced, which has been subjected to misuse, abnormal service or handling, or which has been altered or modified in design or construction.

In order to enforce the rights under this limited warranty, the purchaser should follow the steps set forth below and provide proof of purchase to National.

The limited warranty described herein is in addition to whatever implied warranties may be granted to purchasers by law. All implied warranties including the warranties of merchantability and fitness for use are limited to the periods from the date of purchase as set forth below. Some states do not allow time limitations on an implied warranty, so the above limitation may not apply to you.

Neither the sales person of the seller, nor any other person, is authorized to make any other warranties other than those described herein, or to extend the duration of any warranties beyond the time period described herein on behalf of National.

The warranties described herein shall be the sole and exclusive warranties granted by National and shall be the sole and exclusive remedy available to the purchaser. Correction of defects in the manner and for the period of time described herein, shall constitute complete fulfillment of all liabilities and responsibilities of National to the purchaser with respect to the product and shall constitute full satisfaction of all claims, whether based on contract, negligence, strict liability or otherwise. In no event shall National be liable, or in any way responsible for any damage or defects in the product which were caused by repairs or attempted repairs performed by anyone other than National. Nor shall National be liable, or in any way responsible, for any incidental or consequential, economics or property damage. Some states do not allow the exclusion of incidental or consequential damages, so the above exclusion may not apply to you.

This warranty gives you specific legal rights. You may also have other rights which vary from state to state.

WARRANTY PERIOD

The 72 High Performance Powered Carpet Puller is guaranteed to be free of manufacturer defective workmanship and in quality of materials for a period of one year.

Items excluded from warranty coverage, unless found and reported defective immediately upon removal from the original shipping container and before being used by the original purchaser.

A freight damage claim must be filed with the carrier by the purchaser, the shipper cannot file the freight claim.

TO OBTAIN SERVICE CONTACT NATIONAL FLOORING EQUIPMENT, INC. TOLL FREE AT 800-245-0267 FOR A REPAIR AUTHORIZATION NUMBER. COD FREIGHT RETURNS WILL NOT BE ACCEPTED. FREIGHT COLLECT SHIPMENTS WILL NOT BE ACCEPTED. WARRANTY REPAIRS MUST BE ACCOMPANIED BY DATE OF PURCHASE RECEIPT AND A RETURN/REPAIR AUTHORIZATION NUMBER.

RETURN/REPAIR AUTHORIZATION NUMBER: _____

MACHINE SERIAL NUMBER: _____



Made in America Since 1968

9250 Xylon Avenue N • Minneapolis, MN 55445 • U.S.A.
Toll-free 800-245-0267 • Phone 763-315-5300 • Fax 800-648-7124 • Fax 763-535-8255
Web Site: www.nationalequipment.com • E-Mail: info@nationalequipment.com